

Technical Specification



Frequency Range(GHz)	0.5 - 8.0
Gain(dB)	7 Typ.
Polarization	Linear
VSWR	3.0 Max.
Connector	N-Female
Size(mm)	355 x 497
Net Weight(Kg)	0.7 Around

The picture is for reference only.

Outline Drawing (Size: mm)

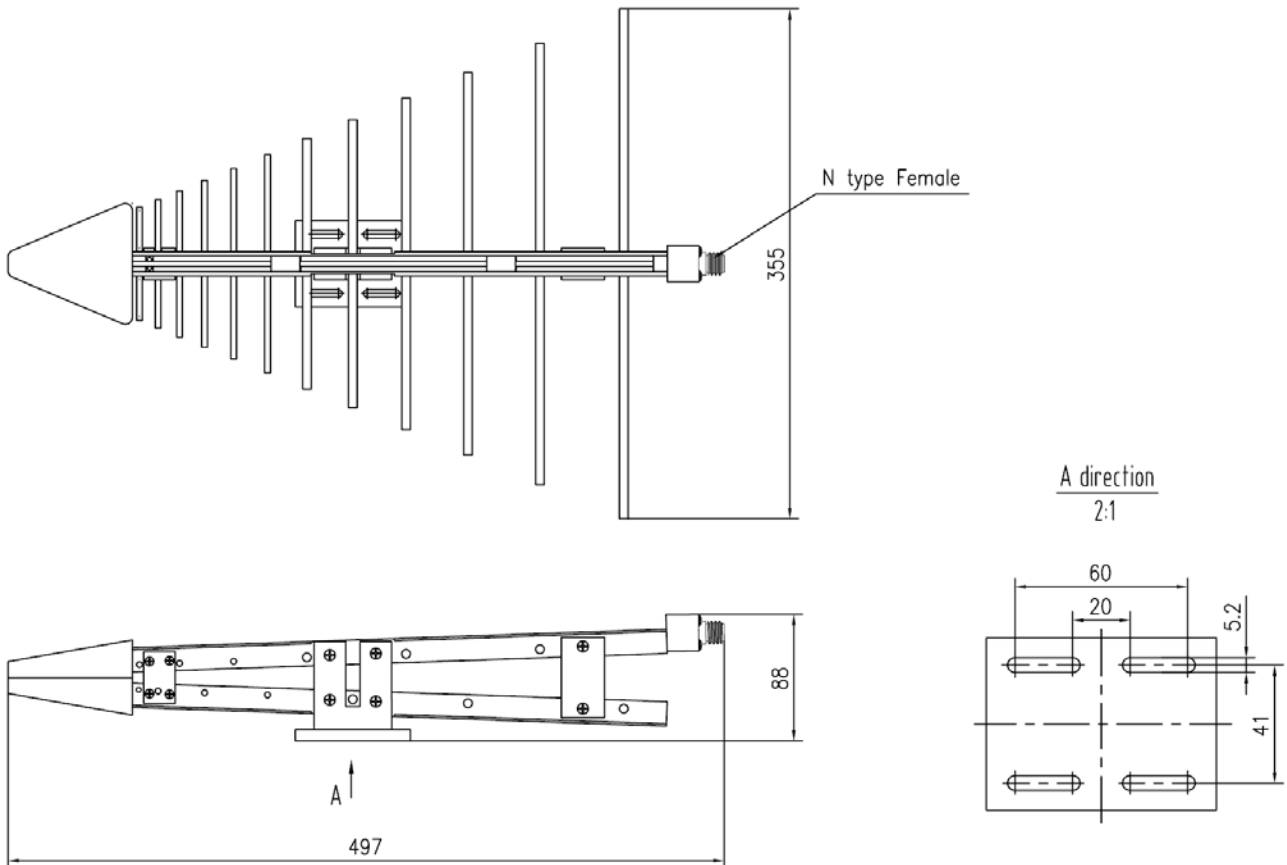

Test Results

1. Gain

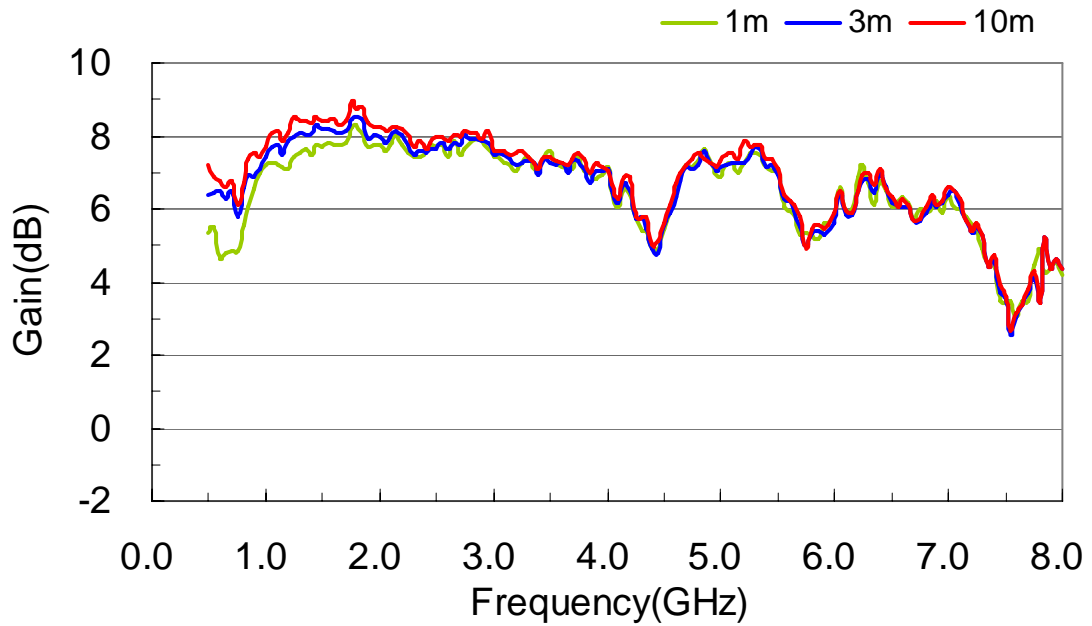

2. Antenna Factor

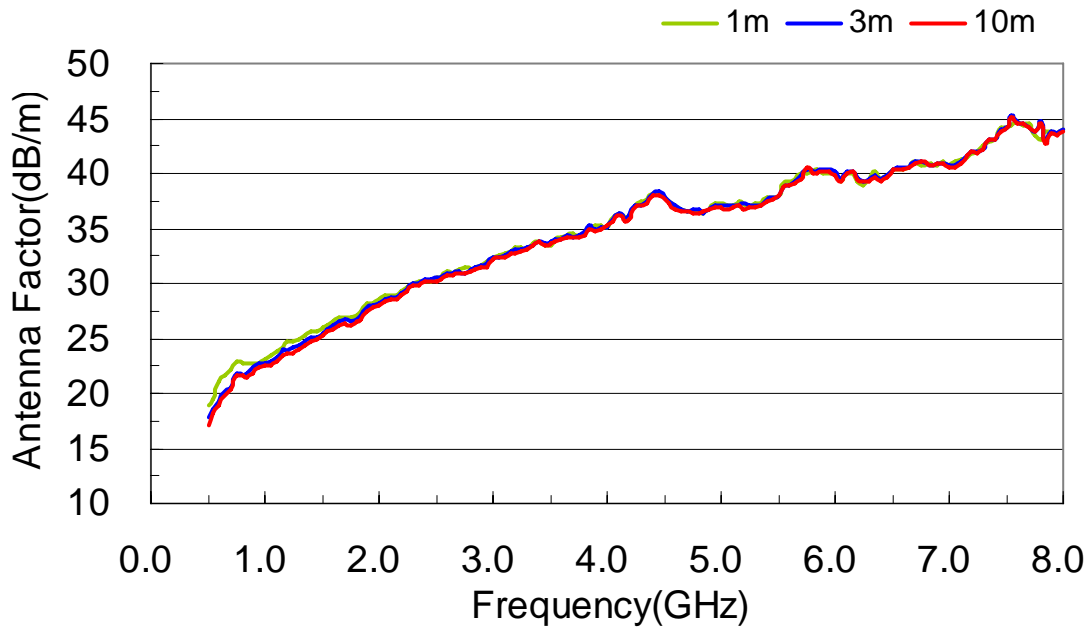

3. VSWR

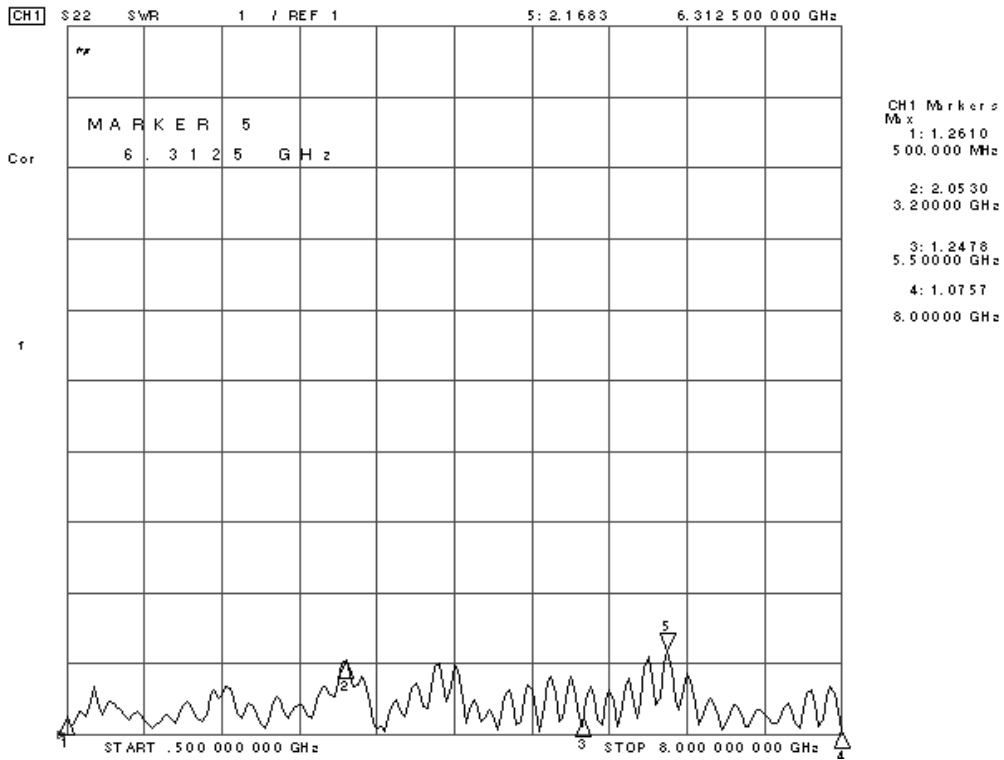

4. Pattern

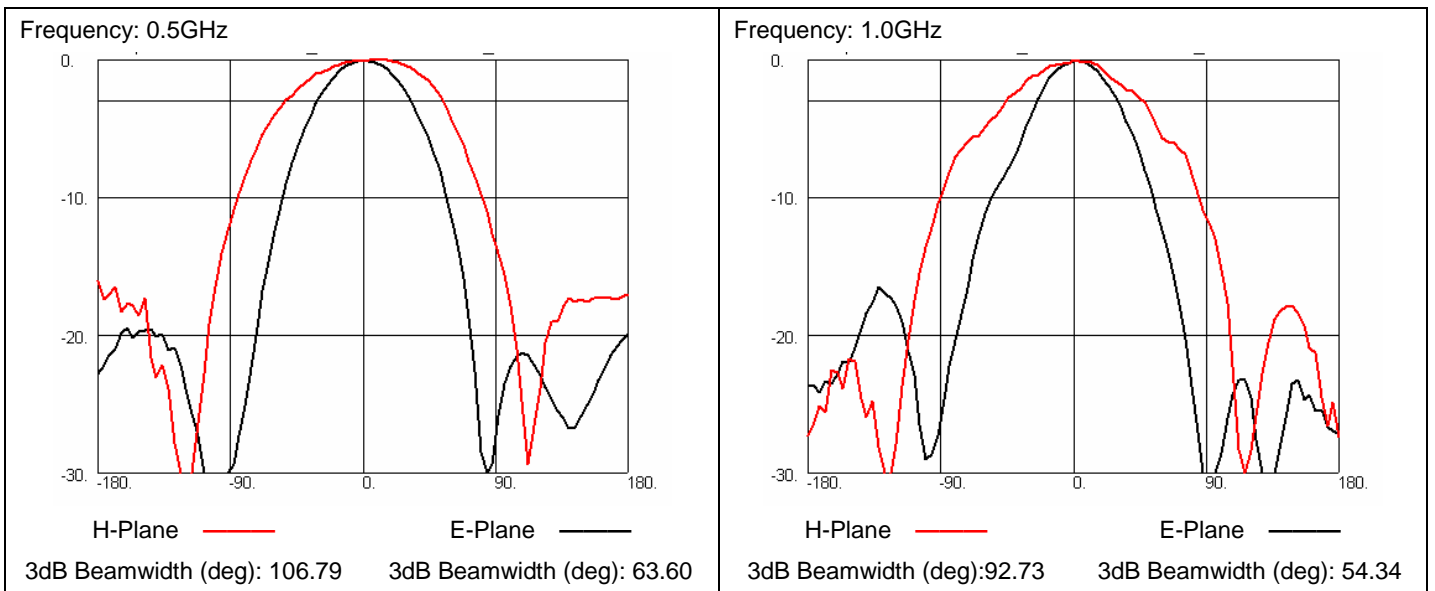

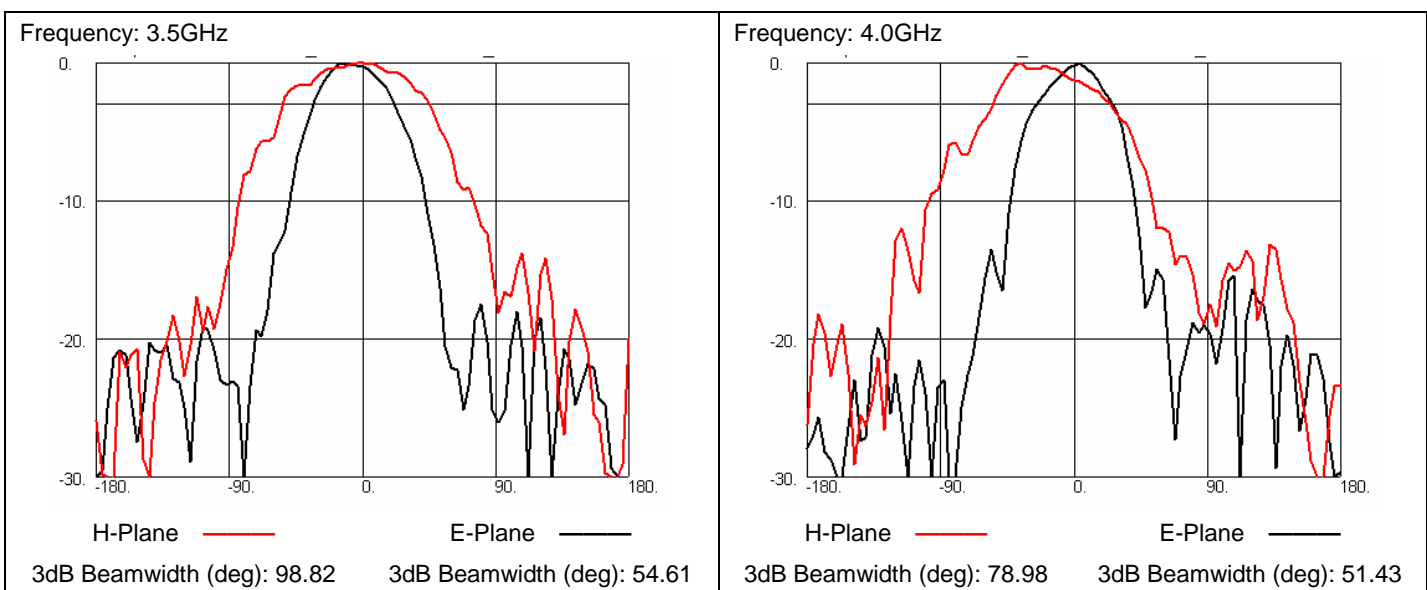
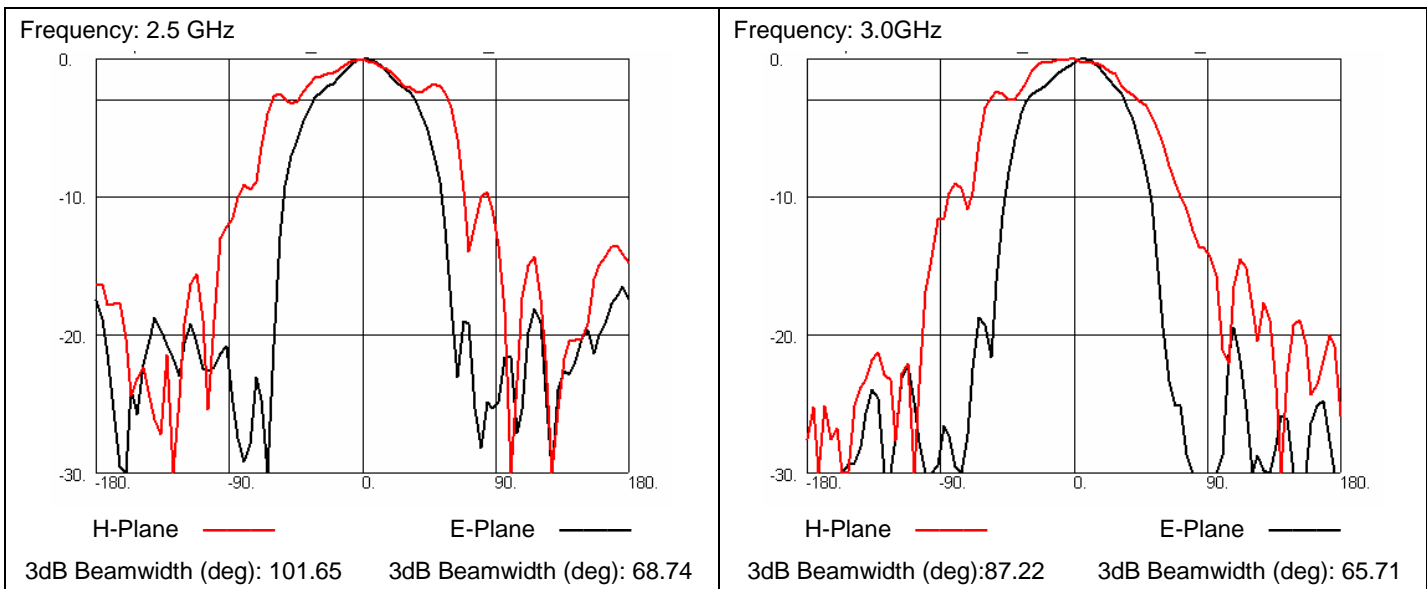
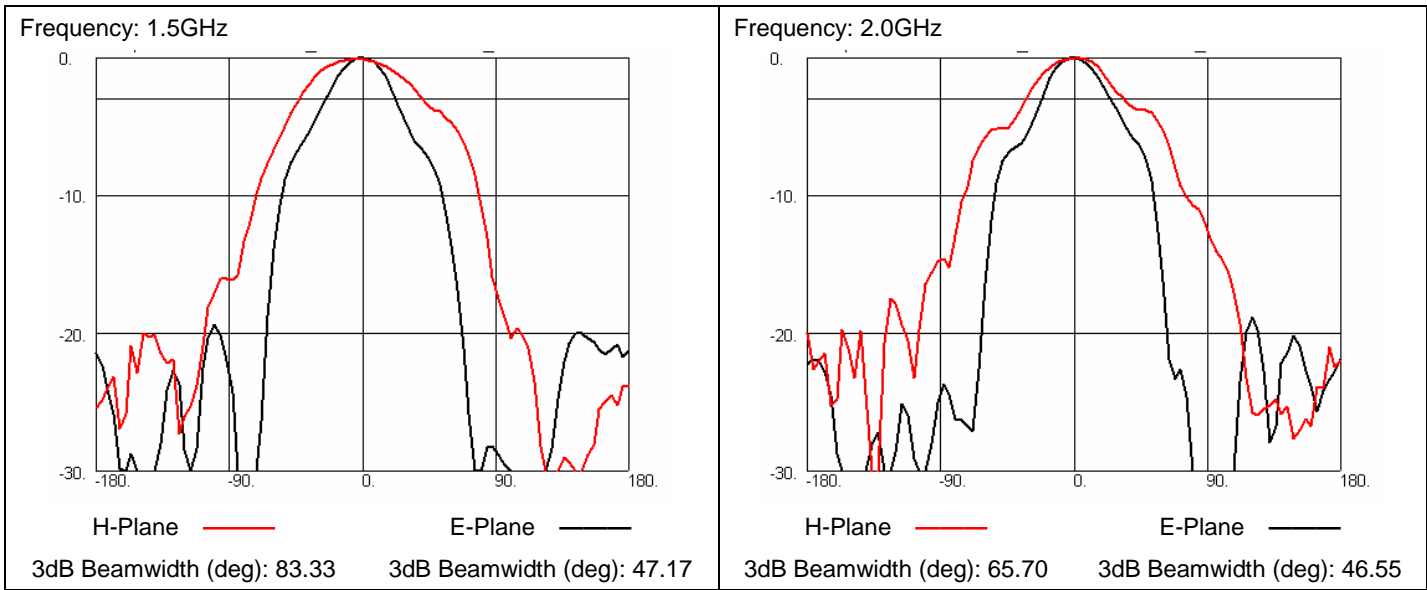

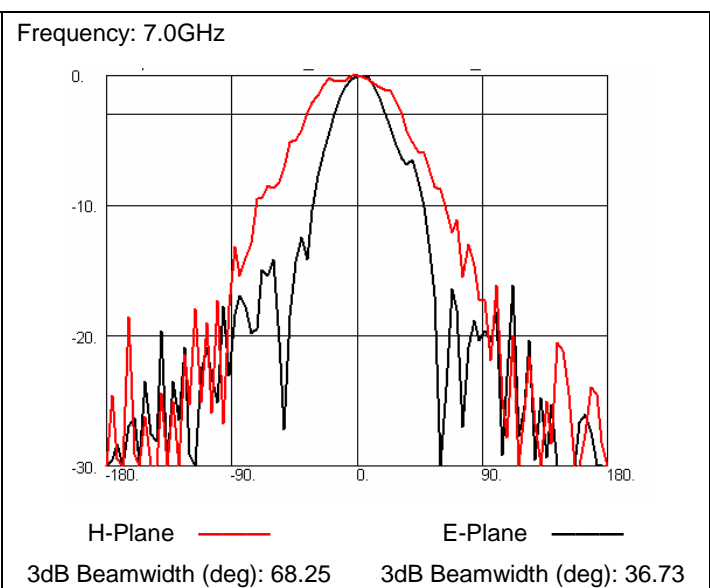
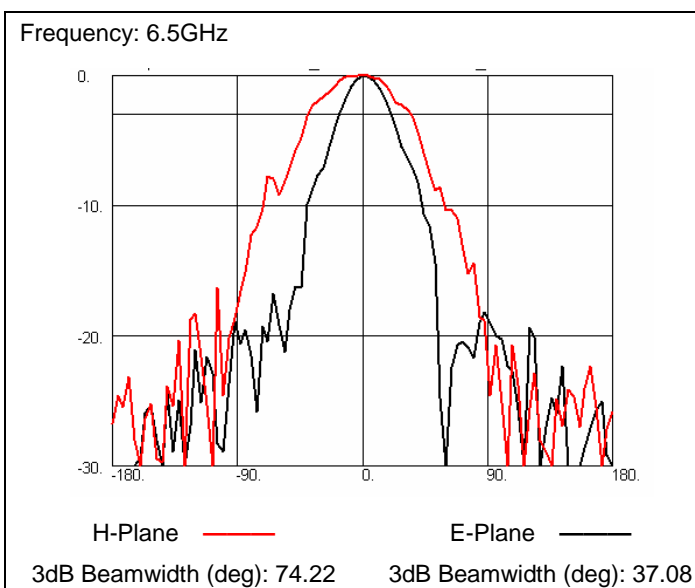
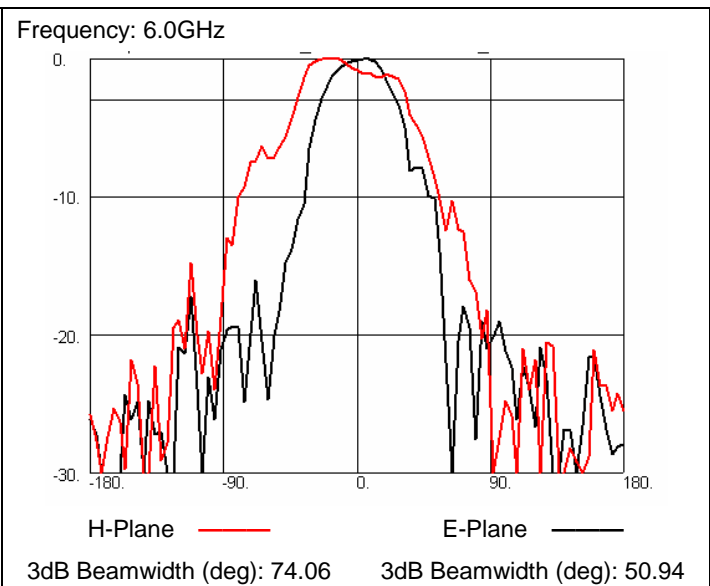
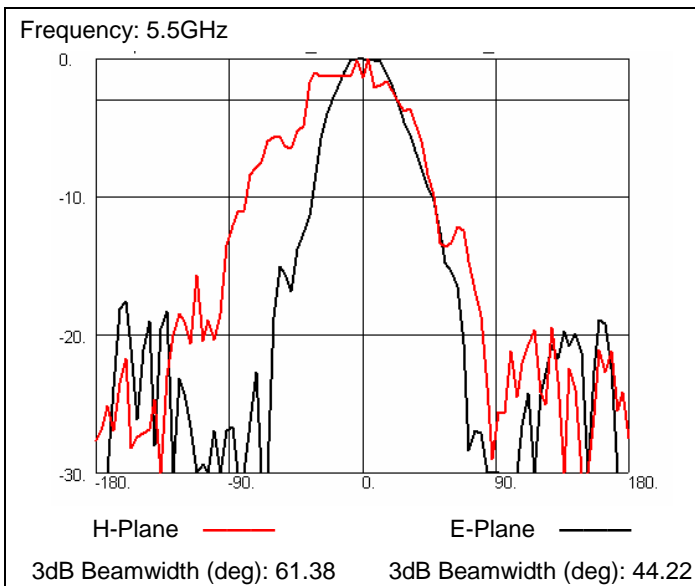
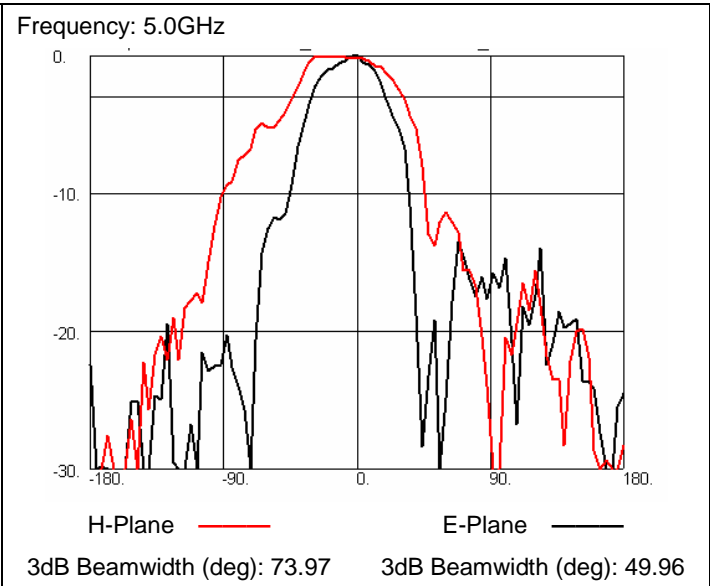
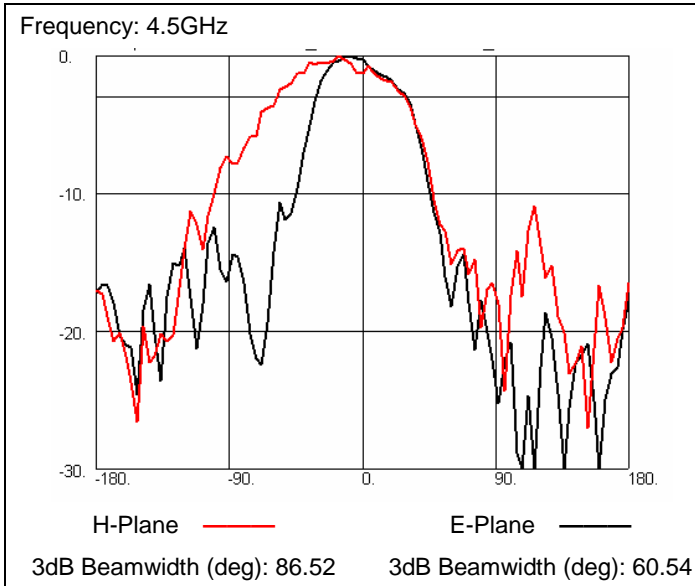

Frequency: 7.5GHz

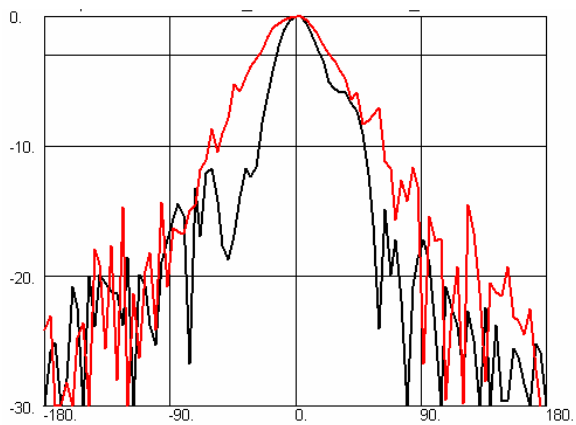

H-Plane —

E-Plane —

3dB Beamwidth (deg): 50.99

3dB Beamwidth (deg): 31.67

Frequency: 8.0GHz

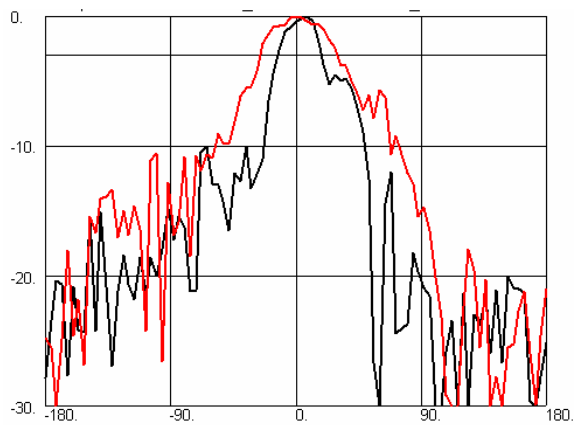

H-Plane —

E-Plane —

3dB Beamwidth (deg): 55.35

3dB Beamwidth (deg): 31.21